

DesignLine
SYNERGY™



**LOW TEMPERATURE
HIGH EFFICIENCY
BASEBOARD RADIATION**

MEETING TODAY'S GREEN INITIATIVES...

Today's high efficiency modulating boilers are designed to operate in a condensing mode for optimal energy efficiency. Simply replacing an older boiler with a new unit is not enough.

Traditional hot water heating systems are designed around temperatures above that of condensing applications and do not see the low supply and return water temperatures necessary for maximum efficiency.

Typical hot water baseboard radiation systems use standard supply water temperatures of 180° which is circulated through the copper and aluminum fin tube piping arrangement to heat the desired space and returns back to the boiler at approximately 160° (20° Delta T). This standard operating configuration leaves boiler operation above that of a true condensing mode thus limiting the efficiency potential of today's modern boiler equipment.

Synergy, Designline's new low temperature baseboard allows today's modern high efficiency modulating boilers to operate at their full potential maximizing system efficiency providing building owners with all the cost-saving benefits of their new condensing boiler.

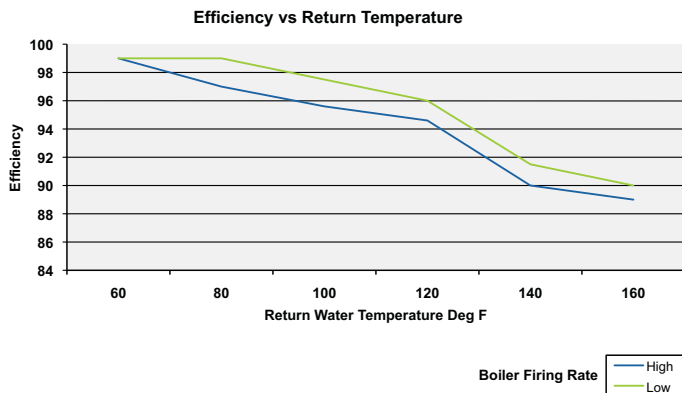

Clean and Green

Synergy baseboard radiation uses standard hydronic fin-tube to provide clean uniform heat and its low temperature design maximizes boiler system efficiency resulting in more useful energy at less of a cost. Get more, Pay less!

Low Cost Alternative

Low temperature baseboard is the low cost alternative to expensive radiant floor, panel radiators and ceiling applications and is the perfect complement for today's high efficiency modulating boiler equipment.

Healthy Hydronic Comfort

Hydronic heating provides the most comfortable and efficient method of heating available. Hydronic systems are versatile and easily zoned for individual comfort while maintaining balanced humidity levels. Hydronic systems do not use fans that can circulate dust and allergens causing unhealthy living environments for all occupants.

Installation Friendly

Synergy low temperature baseboard radiation installs just like traditional fin-tube radiation. No special tools, no secret techniques. Simply put.....installation is easy!



Made In the USA

Designline is manufactured by Sterling Hydronics, a division of Mestek, Inc. and is the number one manufacturer of fin-tube radiation in North America. Headquartered in Westfield, Massachusetts, Sterling was established in 1946 and brings to you the most experienced and cost effective methods of producing high efficiency fin-tube radiation available today.





FEATURES AND BENEFITS

- Lower Temperatures - Premium Performance
- Durable Design
- Aesthetically Pleasing
- Residential & Light Commercial Applications
- Unique Fin Design for Maximum Heat Transfer
- White Baked Enamel Finish
- Manually Modulating Damper
- Clean Hydronic Heat
- Easy Installation

Application Flexibility

Synergy's heavy-duty design is aesthetically appealing and stylish and can be used in both residential and light commercial applications.

Synergy's unique element design allows installation in both low-temperature condensing boiler applications as well as standard or high output applications, providing maximum output at variable supply water temperatures.

Whether you need 2', 8', or anything in between Synergy covers all sizes in both complete (enclosure and element) or enclosure only configurations.

Appealing Durable Design

Residential or light commercial, Synergy is ideal for high traffic areas including offices, apartments, building entry-ways and corridors.

All Synergy enclosures are manufactured using durable 18 gauge steel panels with a beautiful white baked enamel finish that easily blends with any décor. Individual room temperature control made easy through finger-touch adjustable dampers and Synergy's "easy-glide" expansion cradles insure noise free operation. Optional "easy-glide" cradles are available for return piping installations.

Snap-On Dampers

Finger touch snap-on damper opens and closes with ease without the use of hinges that can bind or loosen with age.

Heavy Duty Enclosure

Durable 18-gauge steel enclosure – Industry's best. 16-gauge option available.

Rugged Support Brackets

Strong heavy-duty support brackets built to last.

Unique Element Design for Easy Installation

Copper & aluminum heating elements are mechanically bonded and incorporate expanded ends for easy sweat connections without couplings.

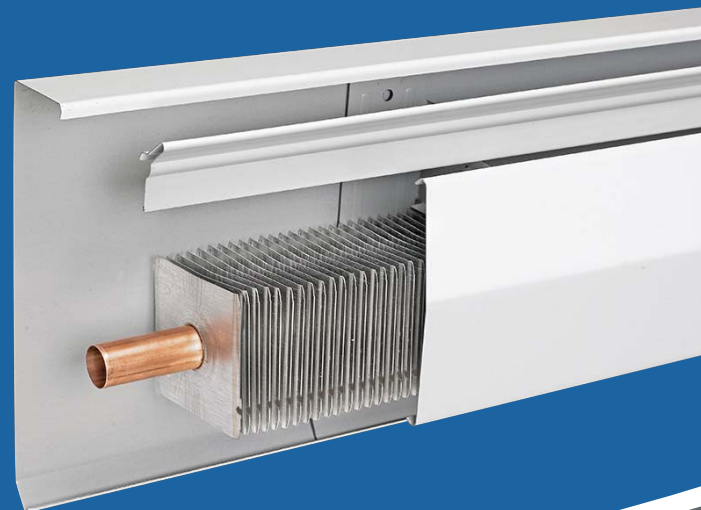

SPECIFICATIONS

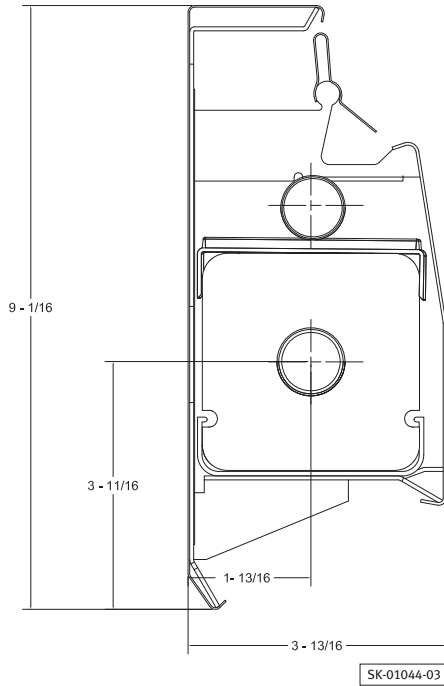

AVERAGE HOT WATER TEMPERATURE °F - BTU/HR./LIN. FT.

GPM	120°	130°	140°	150°
4	328	411	502	597
1	312	390	477	567

Outputs based on:

- Fin-tube element dimensions 3¼" x 3¼"
- 51 fins per foot

ACCESSORIES

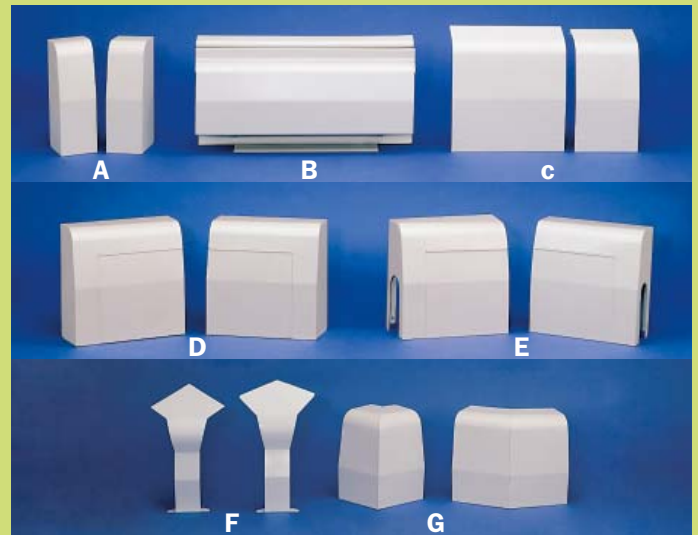

A - End Caps - 3" wide left (LT-EL) and right (LT-ER), for use at doorways and wherever a finished end is needed. 3" wide slotted left (LT-SEL) and right (LT-SER), for through-the-wall connections. Fully telescopic.

B - Extension Sets - 14" wide (LT-EXT14). Four sections (back, front, top and damper). Telescopes to fill gaps up to 12 ½" between baseboard panels.

C - Wall Joiners - 5" (LT-WJ5) and 9" (LT-WJ9). Fully telescopic to conceal connecting pipes.

D - Valve Enclosure - 9" wide left (LT-VL) and right (LT-VR). Extra wide 6" hinged door for easy access to valve or vent. Fully telescopic.

E - Valve Enclosure (slotted) - 9" wide left (LT-SVL) and right (LT-SVR). Extra wide 6" hinged door for easy access to valve or vent. Fully telescopic.

F - Inside Corner - 90° (LT-IC90) and 135°/45° (LT-IC135). One piece snap-on for easy installation. Telescopic up to 2 ½" on each wall.

G - Outside corner - 90° (LT-OC90) and 135°/45° (LT-OC135). Use to trim corners at projecting wall. Telescopic up to 1" on each wall.

DesignLine

260 North Elm Street, Westfield, MA 01085
Tel: (413) 564-5545 Fax: (413) 572-3764

7555 Tranmere Drive, Mississauga, Ontario, L5S 1L4 Canada
Tel: (905) 672-2991 Fax: (905) 672-2883



www.designlineonline.com

DL-SG-1